

SCORPIO 550  
ASSEMBLY INSTRUCTIONS

Serie 10.5

- Side. 3 Unloading
- Side. 4-7 Assembling the drawbar
- Side. 8-11 Assembling the wheels
- Side. 12-17 Assembling the rakes
- Side. 18-19 Assembling reflector brackets



## UNLOADING

On export machine the towing eye is mounted on the front beam for easy loading and unloading of machines when the drawbar is not assembled.

Be careful when unloading to avoid damage on the main hydraulic block and hydraulic hoses.

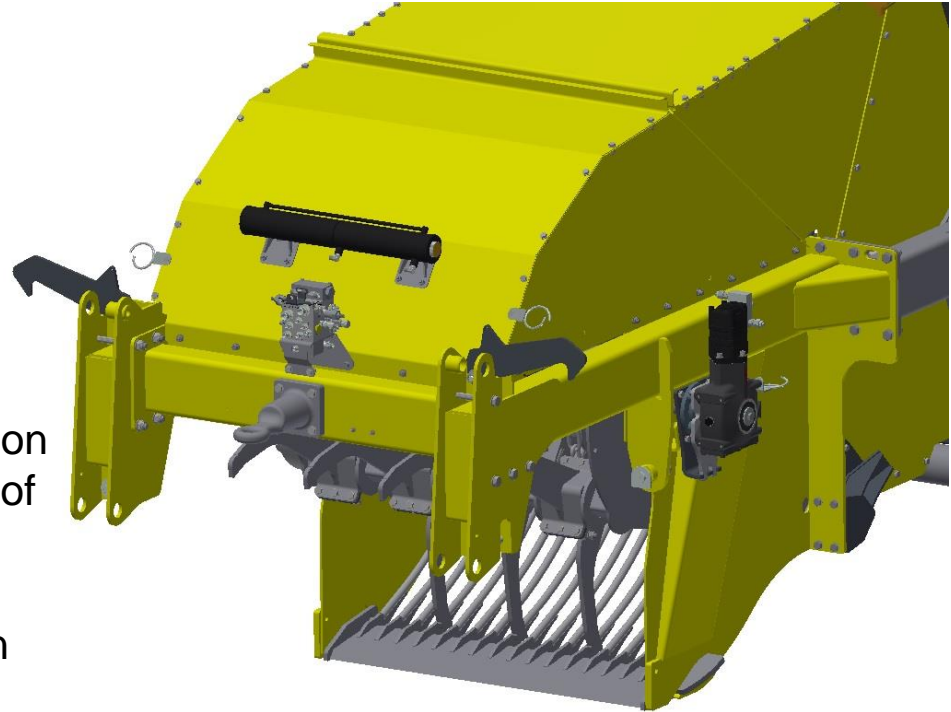

## ASSEMBLING THE DRAWBAR

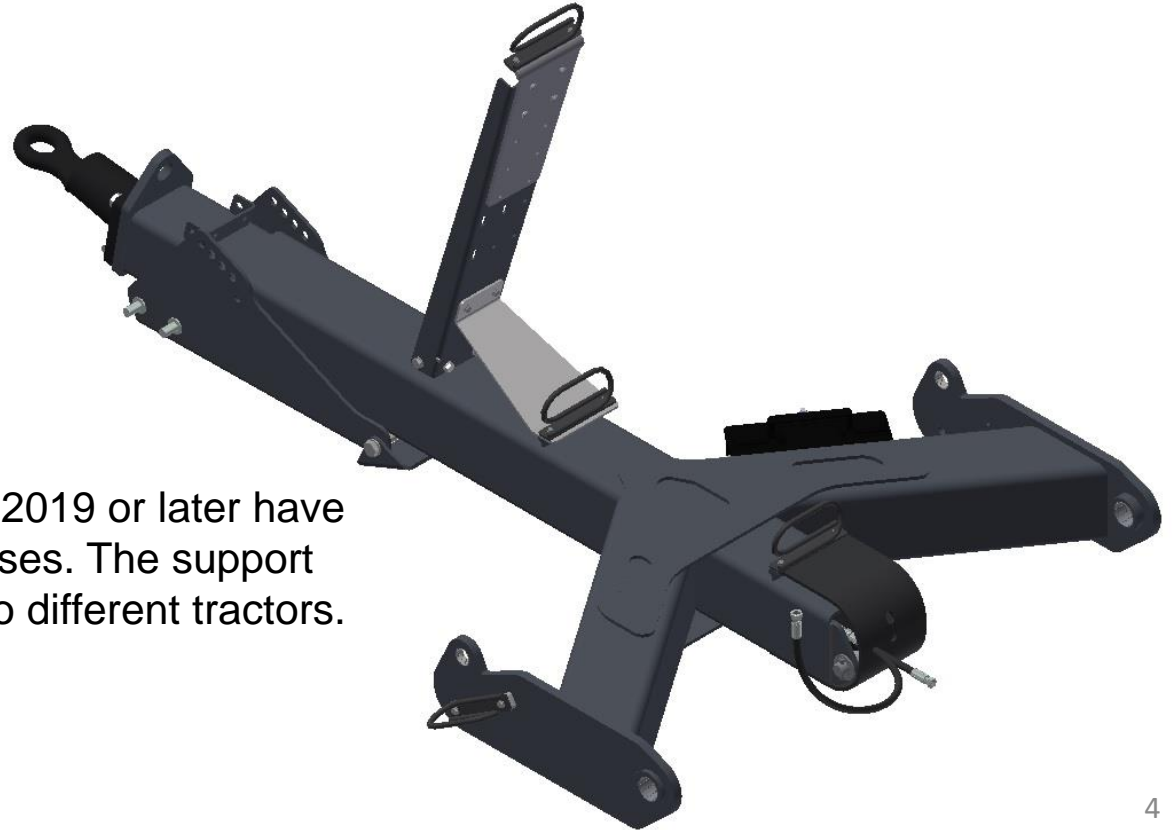

Machines manufactured spring 2019 or later have a new longer support for the hoses. The support height is adjustable according to different tractors.

## ASSEMBLING THE DRAWBAR

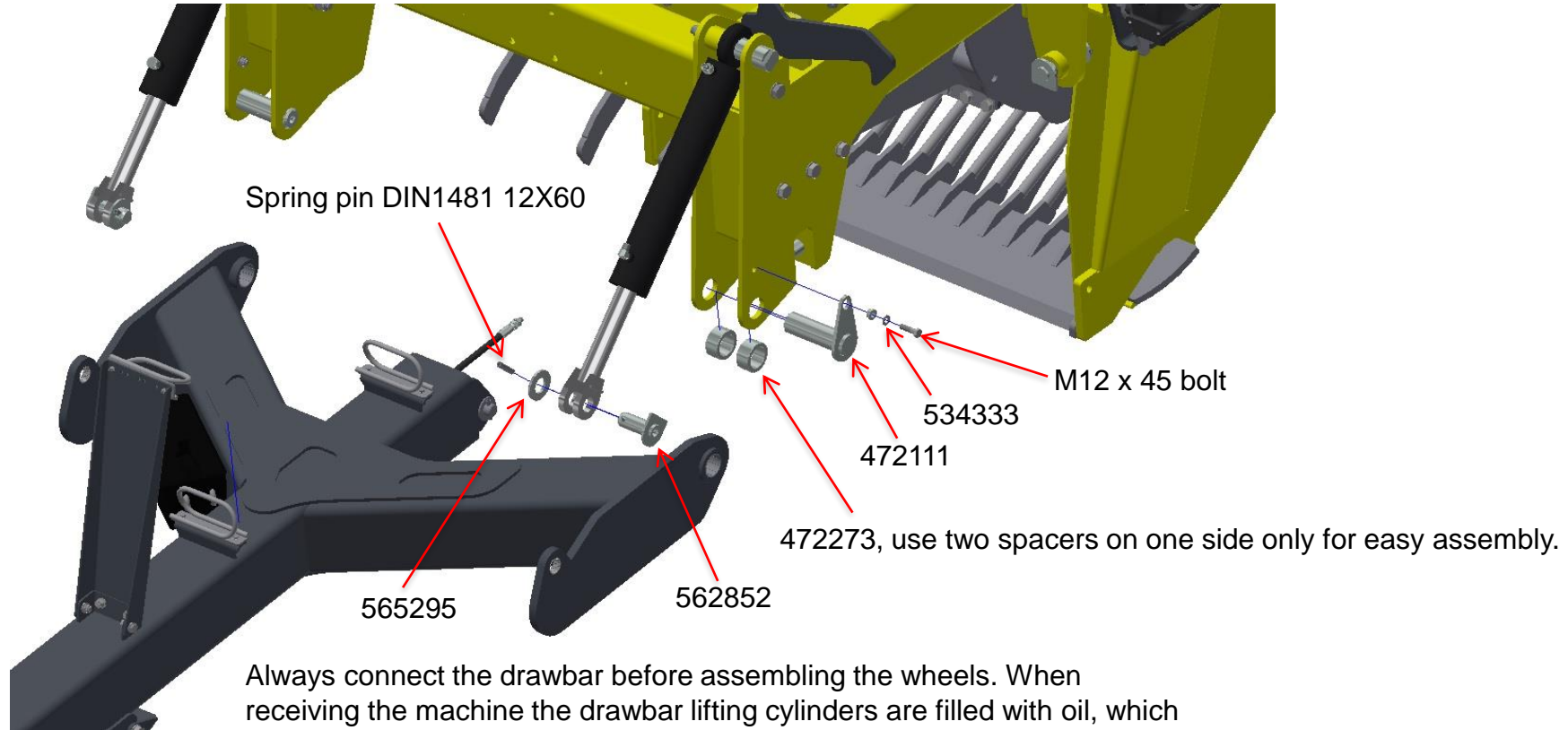

Always connect the drawbar before assembling the wheels. When receiving the machine the drawbar lifting cylinders are filled with oil, which makes the drawbar harder to install after the tandem wheels has been assembled.

## ASSEMBLING THE DRAWBAR

Connect the hydraulic hose from port A to a port marked 2+ and the hose from port B to a port marked T.

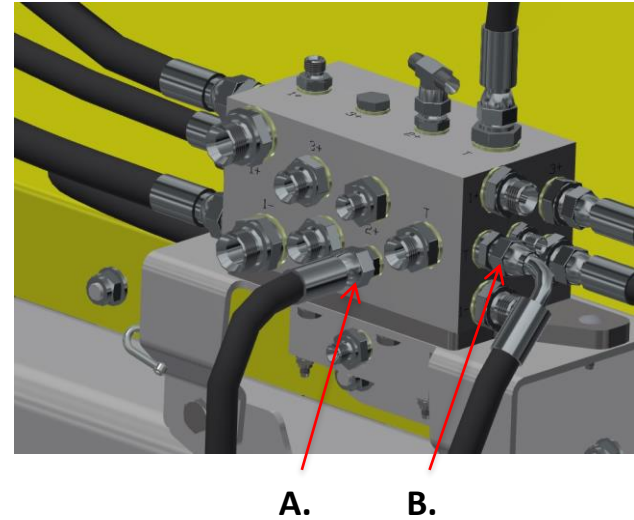
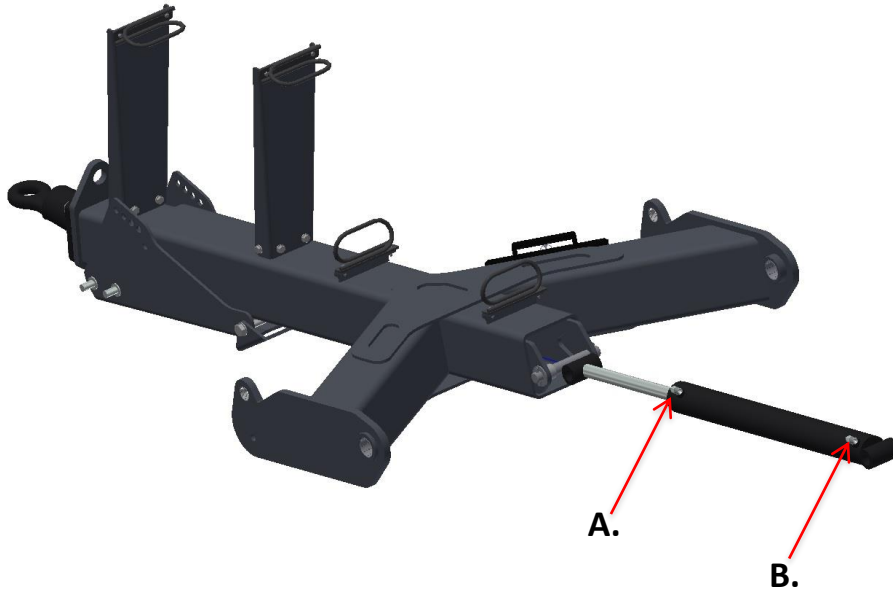

## ASSEMBLING THE DRAWBAR

Remove the towing eye and attach it to the drawbar. Glue and tighten M20x80 bolts to 385 Nm.

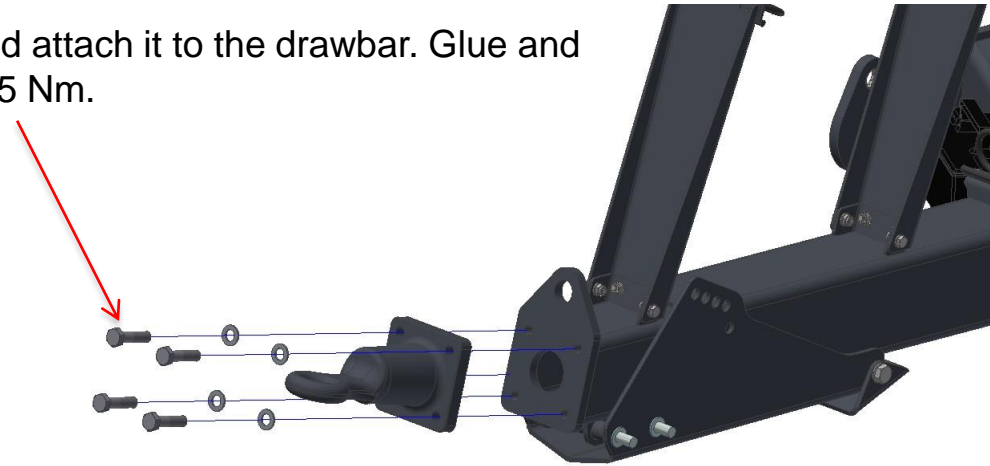
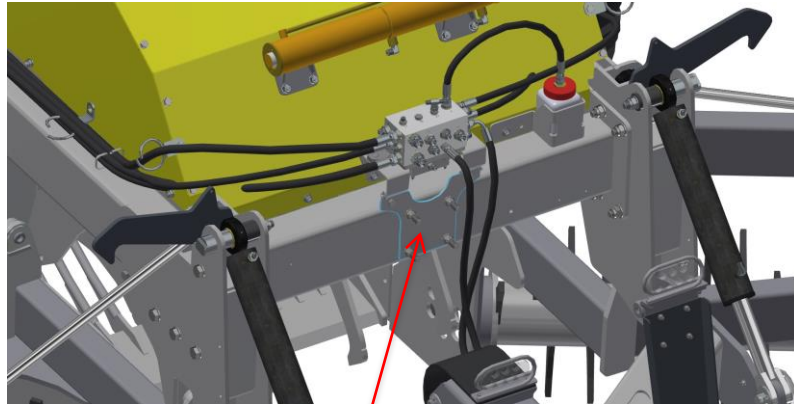

Attach the cover plate, part nr. 472665, with the supplied bolts and connect the bracket for the main hydraulic block.

## ASSEMBLING THE WHEELS

Tapered pin extractor,  
Part nr 472578, is located  
under the long hexbolt nut.

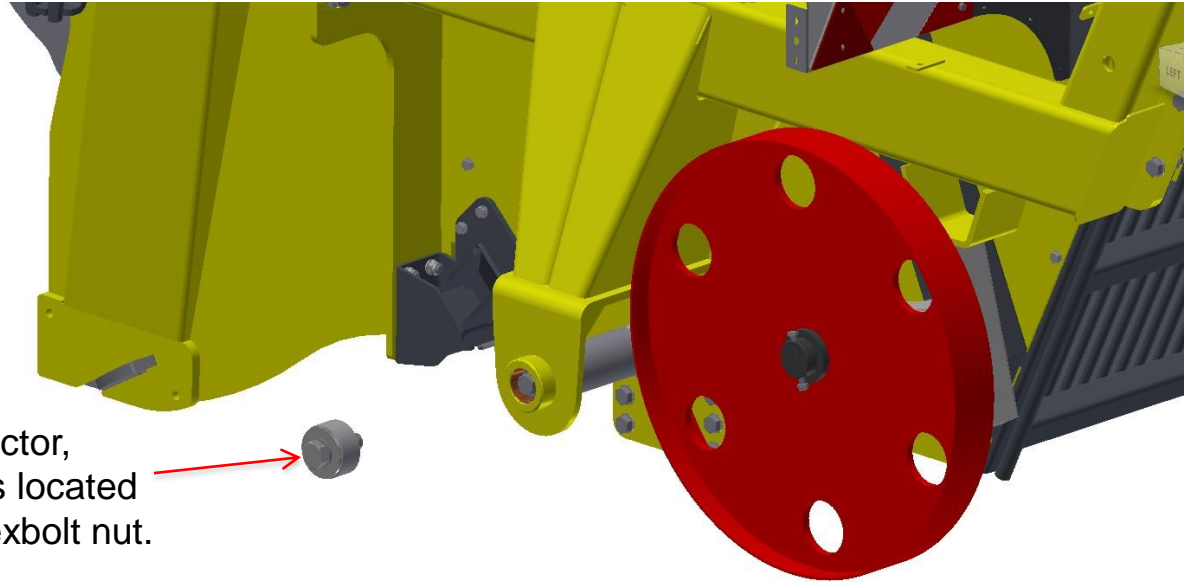

Take care when removing the transportation wheels and attaching the wheels. Make sure the machine is supported before removing any parts.



## ASSEMBLING THE WHEELS

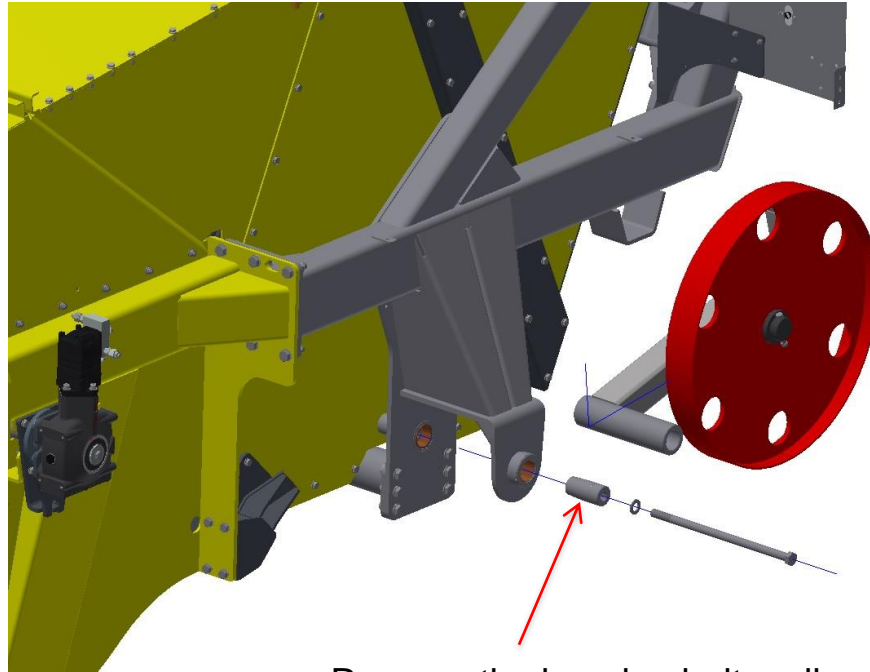

Remove the long hexbolt, pull out both tapered pins and remove the transportation wheels.

## ASSEMBLING THE WHEELS

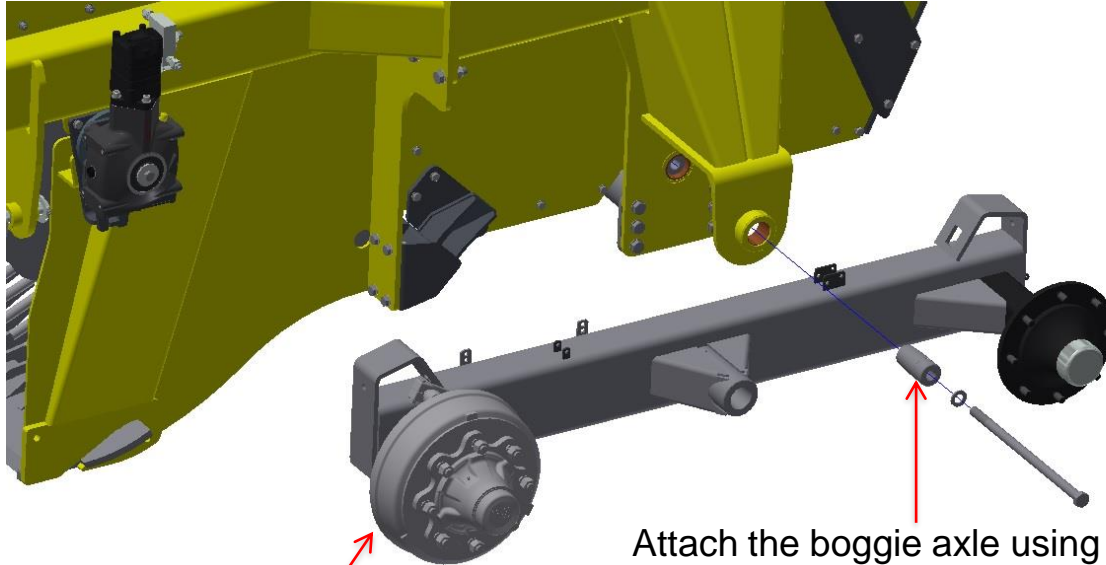

If the machine is supplied with brakes, the brakes should be on the front wheels.

Attach the bogie axle using the same tapered pins.

Tighten the M24 bolt to 935 Nm.

Note! The tapered pins have part nr 472206 and have a length of 120 mm.

## ASSEMBLING THE WHEELS



Attach the wheels using eight wheel nuts, tighten to 450 Nm.

## ASSEMBLING THE RAKES

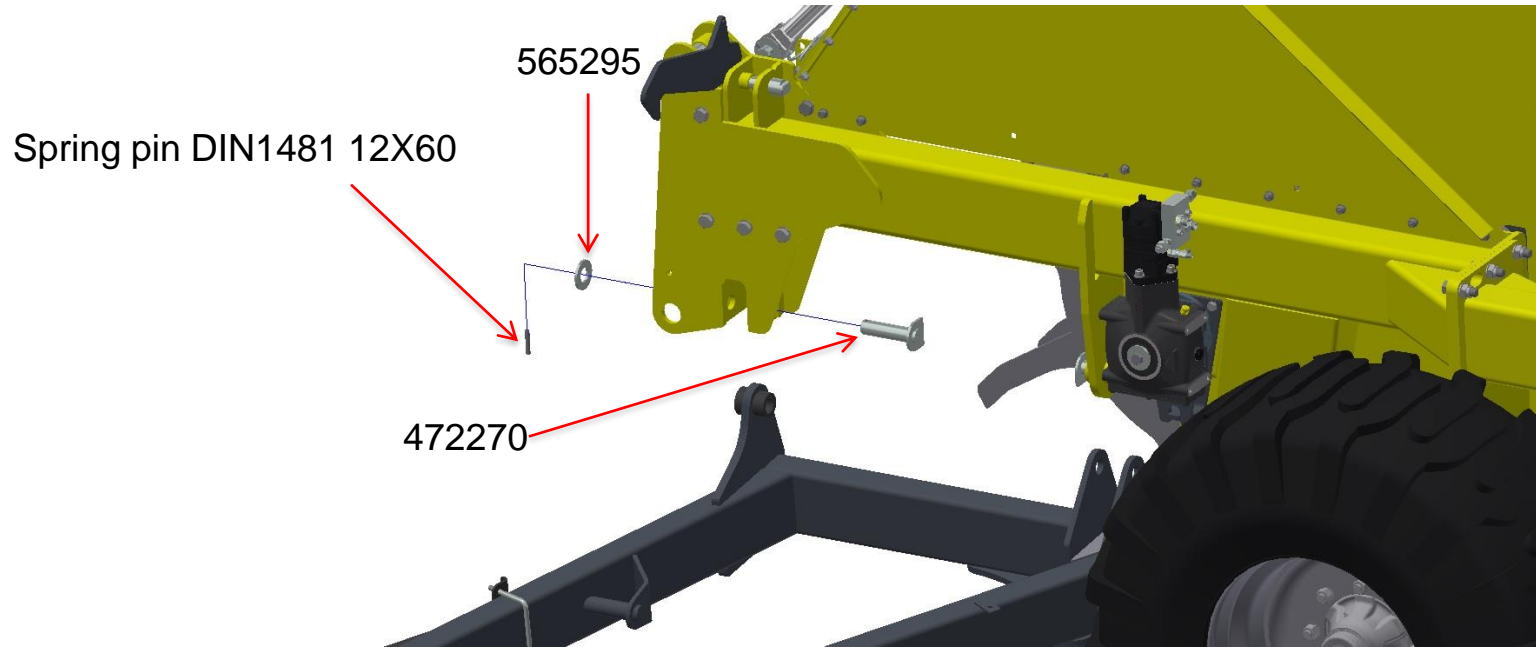

If the rakes are shipped on wooden pallets you can lift the rakes in place while they are still on the pallet. It is recommended to attach the drawbar before assembling the rakes so that you can lift the machine if needed.

# ASSEMBLING THE RAKES

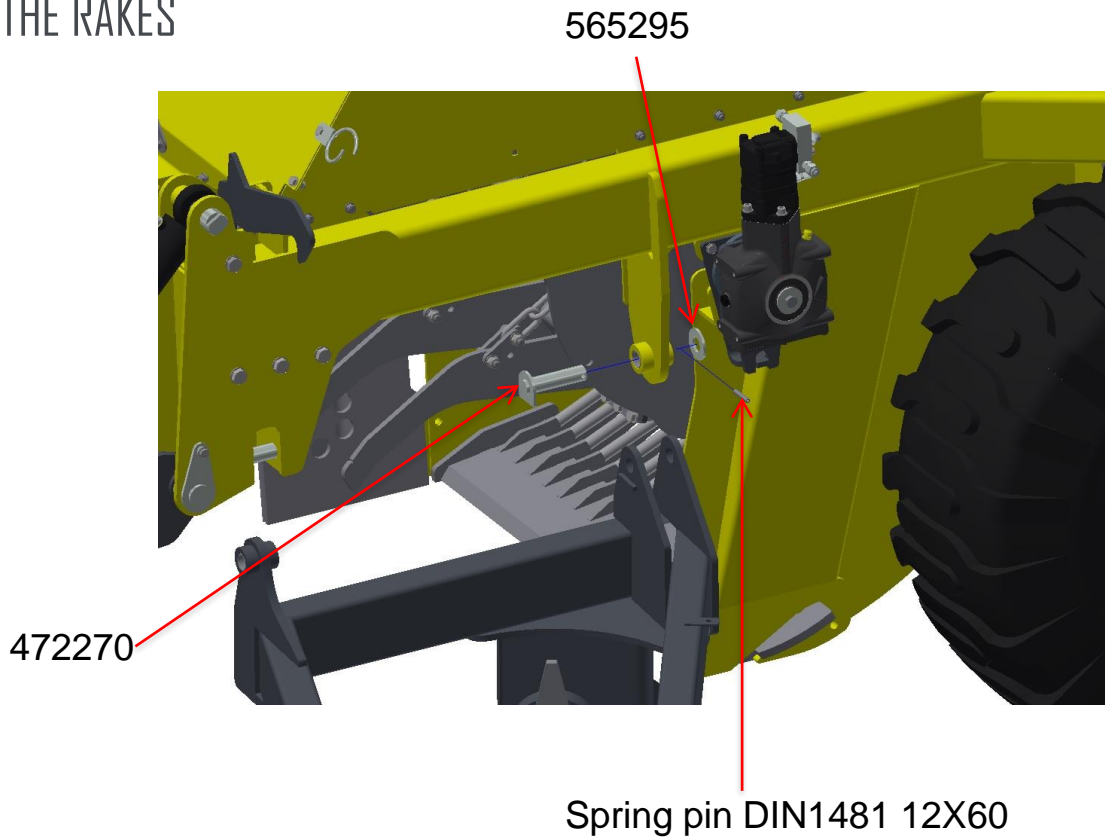



## ASSEMBLING THE RAKES

Assemble the support wheel 200-250 mm from the end plate.



## ASSEMBLING THE RAKES

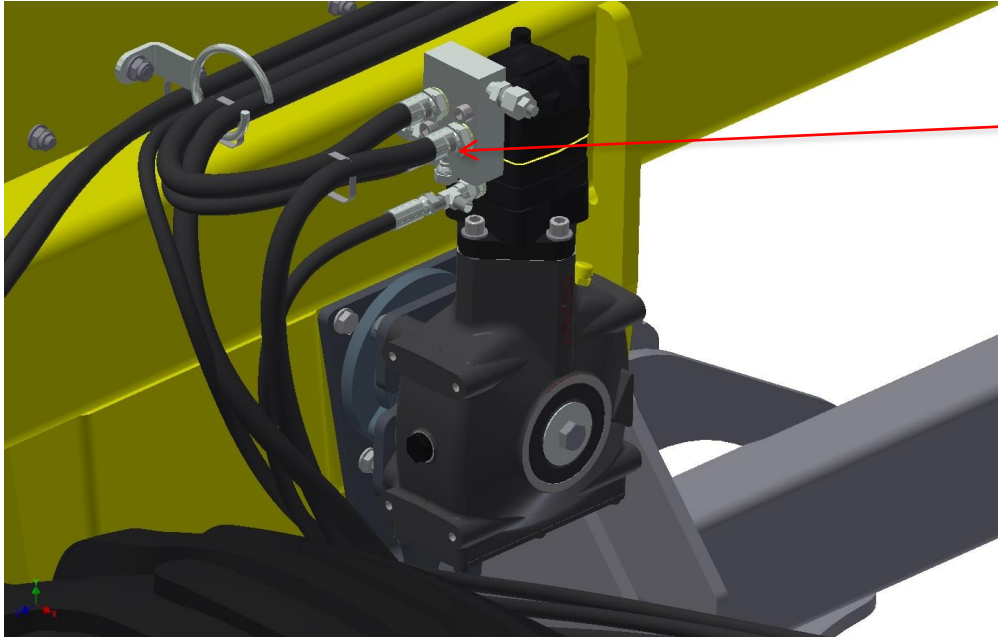

Connect the shorter hose (145669) from the rake motor to the outer port on the shockvalve for the main rotor motors.

## ASSEMBLING THE RAKES

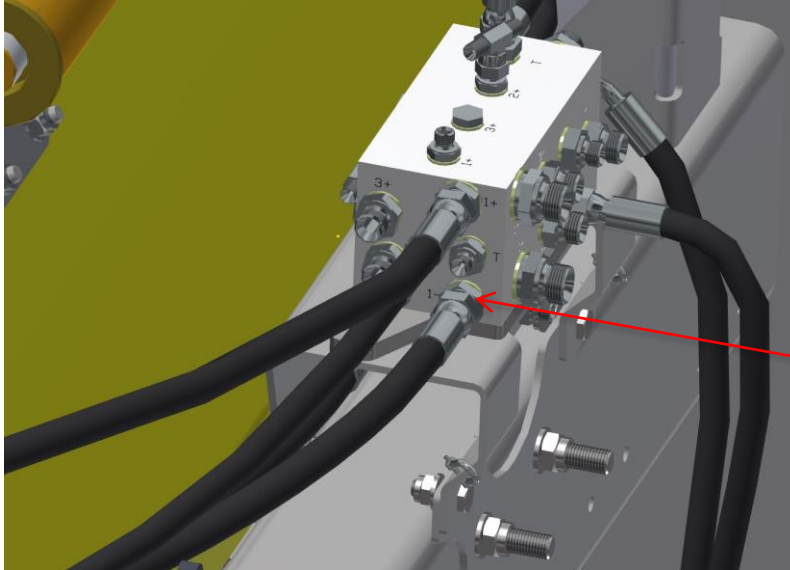

Connect the longer hose (145019) from the rake motors to the main block ports marked R1- for the right side rake and port L1- for the left side rake.



## ASSEMBLING THE RAKES



- Greenline connect to 50/50 divider under main block (4+)
- Redline connects to T-connection on motor drain line (yellow)
- Yellow line connect motor drain ports.

## ASSEMBLING REFLECTOR BRACKETS

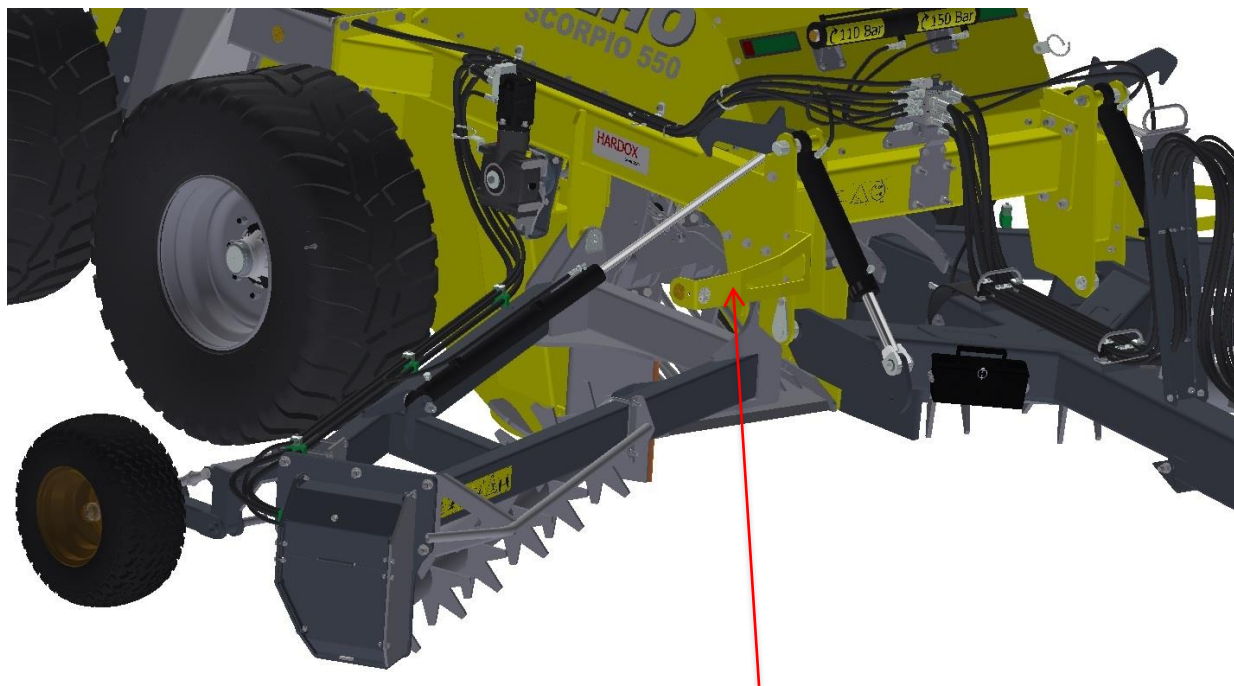

Front reflector brackets

## ASSEMBLING REFLECTOR BRACKETS

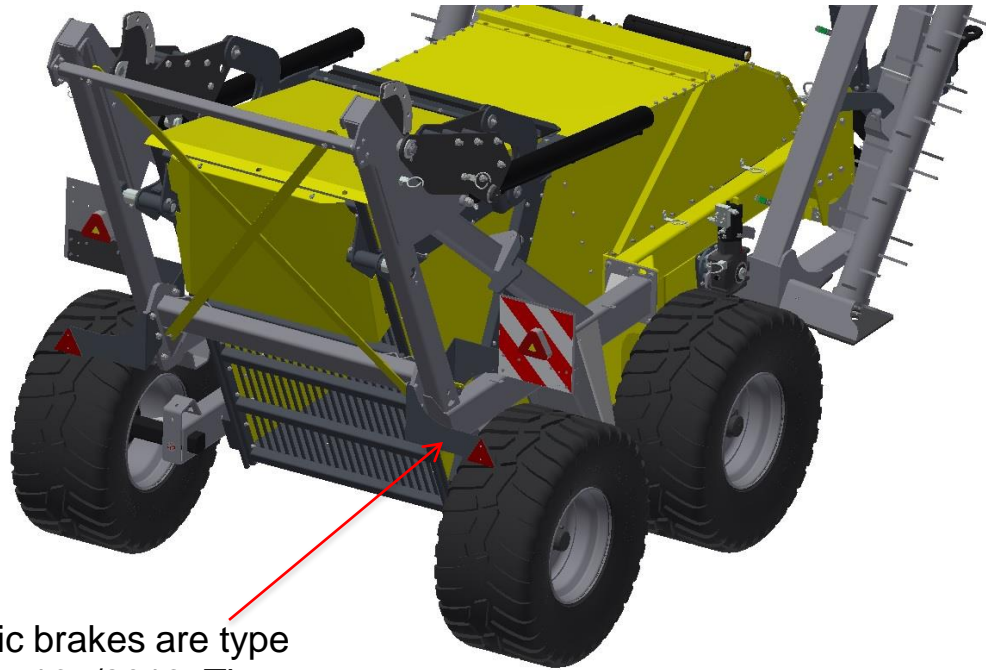

Machines with pneumatic brakes are type approved according to eur167/2013. These machines are delivered with rear reflector brackets.





